

TH 316 TRIODE

The TH 316 is a forced air cooled, ceramic metal, high gain triode of planar structure. This tube is specially designed for highly linear amplifier operating up to 1000 MHz without grid current in T.V. translators handling both sound and vision signals in the same channel with a crossmodulation level better than 52 dB.

The anode can dissipate 270 W.



GENERAL CHARACTERISTICS

Electrical

Type of cathode	oxide coated
Heating	indirect
Heater voltage (1)	5.0 ± 2% V
Heater current, approximate	1.9 A
Minimum preheating time	3 mn
Interelectrode capacitances (2) :	
- grid-anode	3.2 to 4 pF
- grid-cathode (cold)	14.5 to 14.8 pF
- cathode-anode (cold)	0.04 pF max.
Amplification factor, average	230
Transconductance, average ($I_a = 150$ mA)	70 mA/V

Mechanical

Mounting position	any
Anode cooling (3)	forced air (see curves page 4)
Maximum temperature at the top of radiator	see curves page 4
Maximum temperature of electrode terminals (3)	150 °C
Net weight, approximate	170 g
Dimensions	see drawing

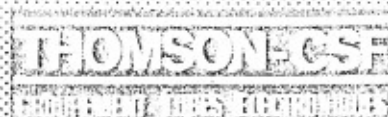

OPERATING CONDITIONS

Maximum ratings

Anode D.C. voltage	2 000	V
Grid D.C. voltage	-50	V
Cathode D.C. current	250	mA
Anode dissipation	270	W
Frequency	1 000	MHz

CLASS A - LINEAR AMPLIFIER FOR TELEVISION TRANSLATOR HANDLING BOTH SOUND AND VISION SIGNALS C.C.I.R. STANDARD

Typical operation

Operating frequency	780	780	MHz
Anode D.C. voltage	1 200	1 500	V
Anode D.C. current	100	100	mA
Gain	20	20	dB
Peak video power	25	35	W
Crossmodulation level (3 tones test)	> 52	> 52	dB*

* Under Video level.

NOTES

- 1 - In high frequency operation, the cathode is subjected to considerable bombardment which raises its temperature. After the circuit has been adjusted for proper tube operation, the heater voltage must be reduced to prevent overheating of the cathode with resulting short life. Ask for information for any special operation.
- 2 - Measurements are made in appropriate mounting with minimum parasitic capacitances.
- 3 - The cooling airflow must be established before any voltage application.



CURRENT CHARACTERISTICS

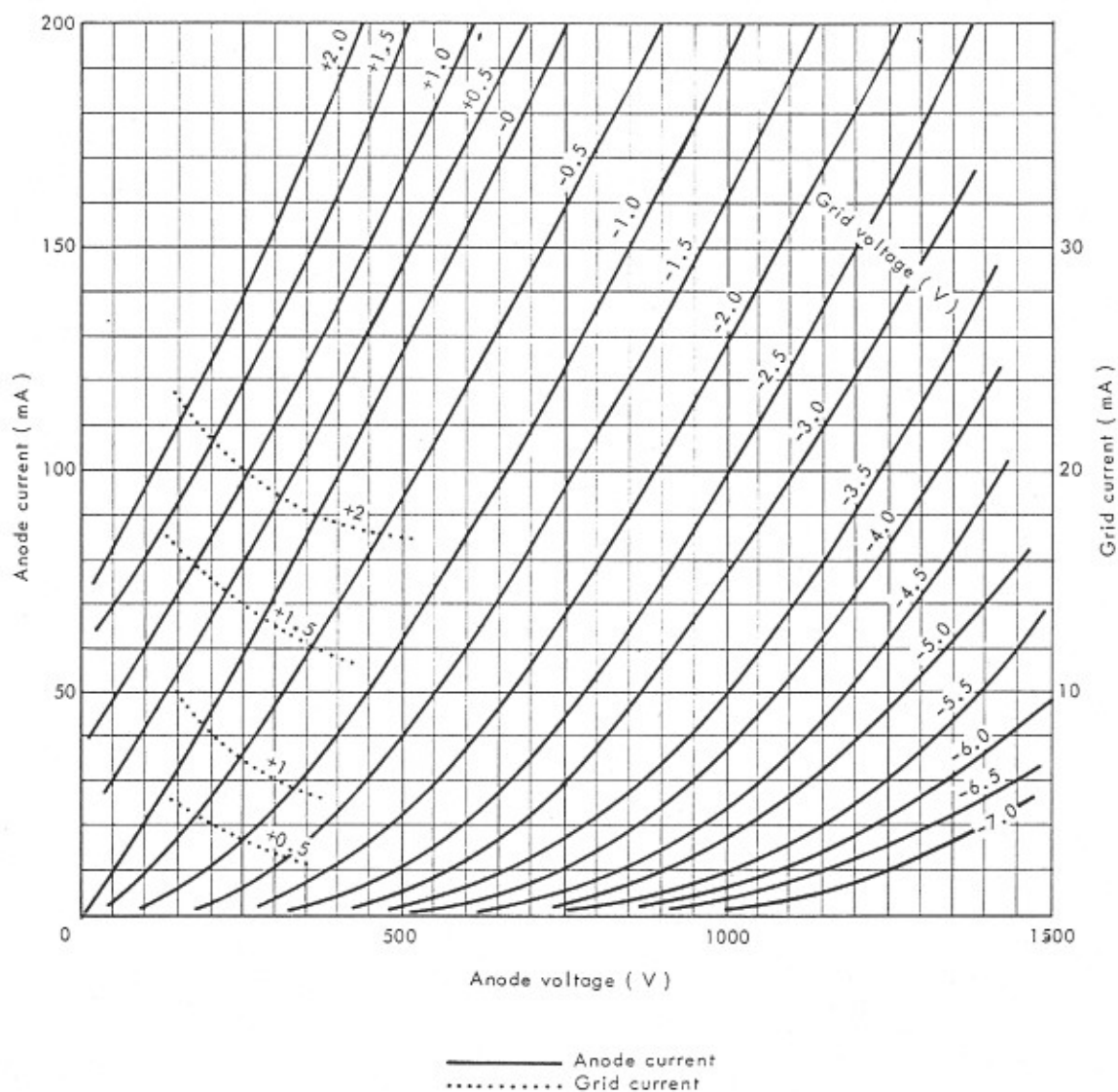

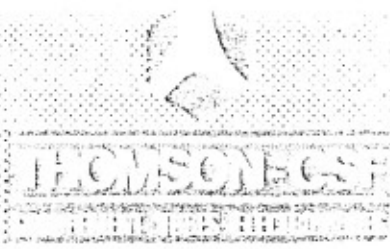

AIRFLOW VERSUS ANODE DISSIPATION
FOR INLET AIR TEMPERATURE OF 20° C

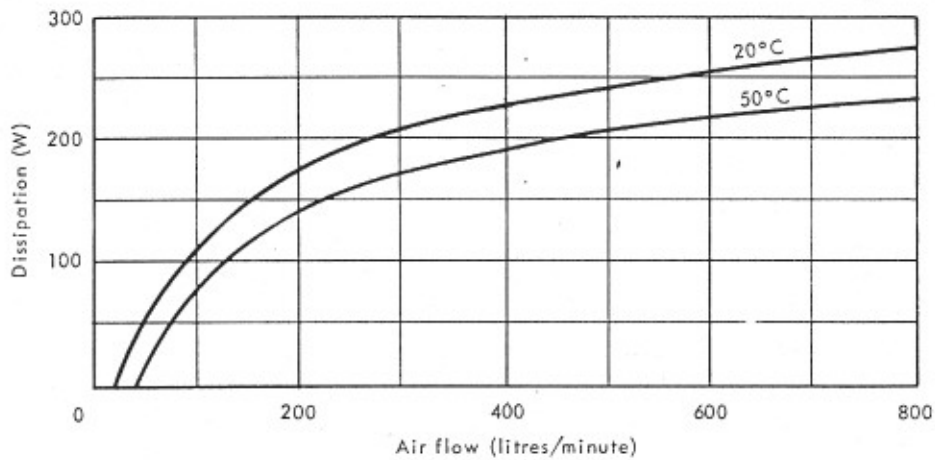

AIR PRESSURE AT THE ENTRANCE OF THE DUCT

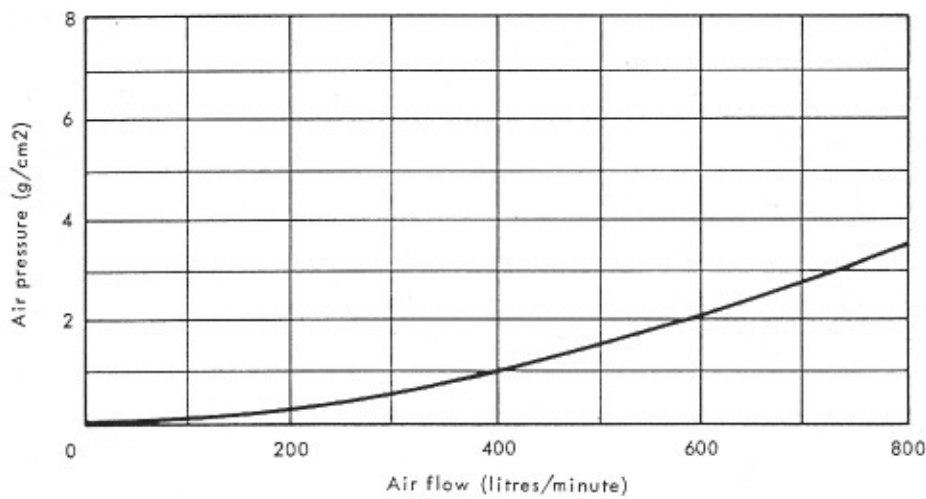

MAXIMUM TEMPERATURE ALLOWED AT THE TOP OF THE RADIATOR

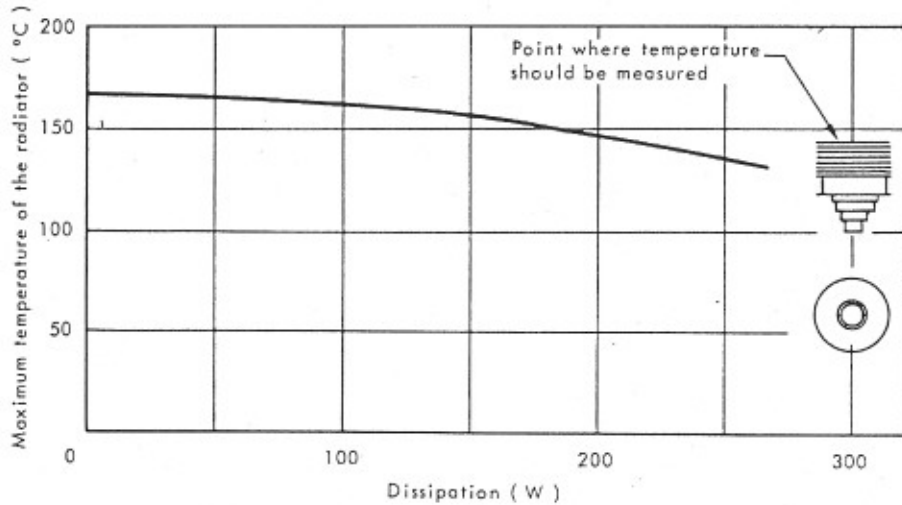

DETAILS OF AIR DUCT

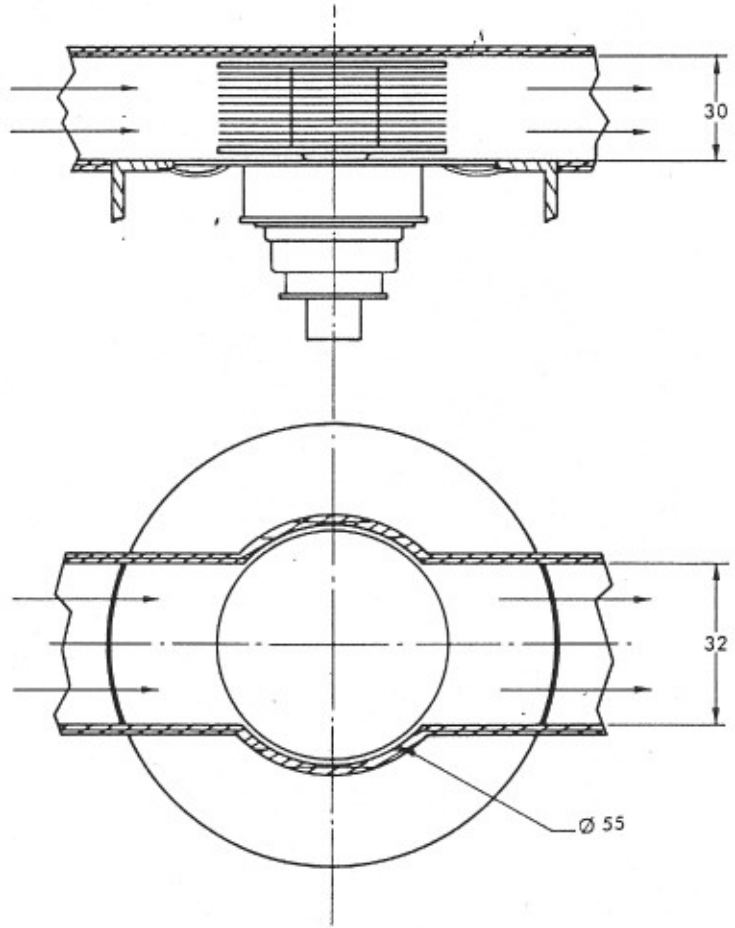

ANODE SPRING CONTACT

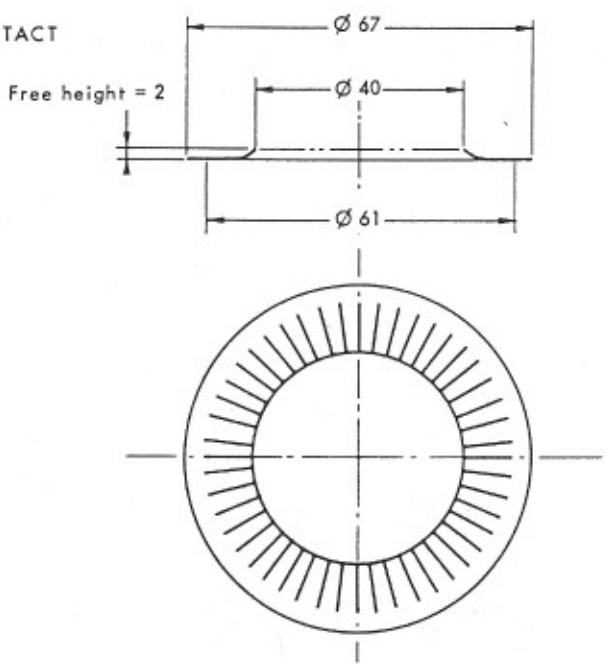

Dimensions in mm.

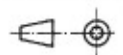

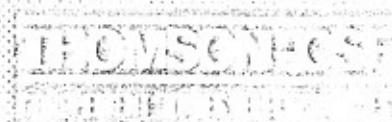

OUTLINE DRAWING

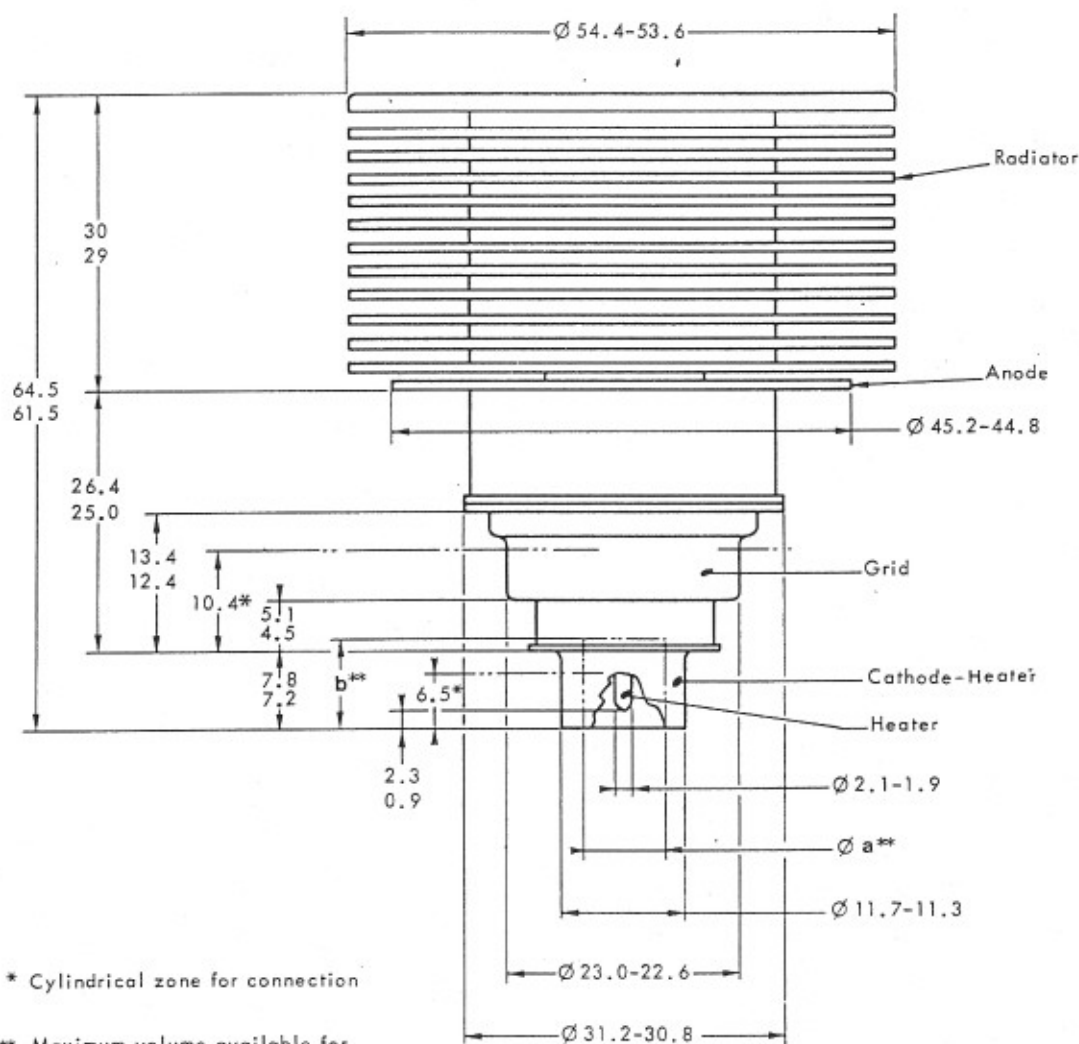

* Cylindrical zone for connection

** Maximum volume available for heater connection :
 $a = 8$ $b = 7.5$