

## TECHNICAL DATA

**AIR-SYSTEMS**  
**SK-800B & SK-801**  
**(Ungrounded Cathode)**  
**SK-810B, SK-811,**  
**& SK-890B**  
**(Grounded Cathode)**  
**AIR CHIMNEY SK-806**

These air-system sockets are recommended for use with 8168/4CX1000A, 8660/4CX1500B, and the 8244/4CW2000A tube types, providing good contact to all tube elements except the anode. A low inductance sealed bypass capacitor is integral to the assembly.

The SK-806 chimney is used with the air-cooled types (4CX100A and 4CX1500B) so that with pressurized-chassis designs the forced air passes through the socket and around the tube base, then through the anode cooling fins.

The electrical characteristics of the sockets are summarized in the following table:

SOCKET	— Bypass Capacitor —		Element Bypassed	Common Contacts
	pF	Voltage DCWV		
SK-800B	1500	400	Screen	None
SK-801	4000	400	Screen	None
SK-810B	1500	400	Screen	Shell, Cath & 1 Htr
SK-811	4000	400	Screen	Shell, Cath & 1 Htr
SK-890B	1500	400	*	Shell, Cath & 1 Htr

\* Bypass capacitor is isolated from screen contacts

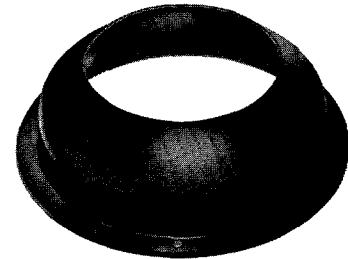
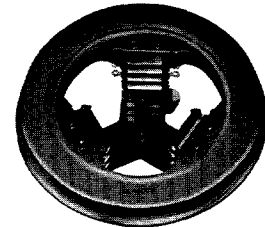

These sockets have similar external appearance and common dimensions.

**BASE CONNECTIONS** - These sockets have three spring-finger contacts for each tube electrode (to assure low-inductance contact), a center guide pin to assure correct tube orientation during installation, and an integral bypass capacitor. The terminals are shown on the outline drawing. The terminal shown as "COMMON GROUND" is a direct connection to the shell of the socket.

**INTEGRAL BYPASS CAPACITOR** - This capacitor utilizes Mylar film as a dielectric and is encapsulated in silicone resin. Its capacitance is 1500 pF  $\pm$  20% or 4000 pF  $\pm$  20%, as shown in the table above, rated at 400 dc working volts. The capacitor bypasses the screen grid to the socket shell with four of the sockets, but in the SK-890B it is isolated from the screen terminals and may be used at the discretion of the circuit designer.

**MATERIALS & FINISHES** - The socket shell, or body, is fabricated of silver-plated brass, while the mounting base and centering pin are a one-piece, nickel-plated die casting. All the contacts are formed of a non-ferrous alloy, heat treated and silver plated. Contact insulating material is a high-alumina ceramic.

**INSTALLATION** - These sockets are designed for under-chassis mounting and require a 5-1/16 inch (12.86 cm) diameter hole through the chassis deck. The socket is held in place by three toe clamps, provided with the socket. With all units except the SK-890B the integral screen grid bypass capacitor is automatically grounded to the chassis when this mounting method is used.



SK-800B, SK-801  
 SK-810B, SK-811  
 SK-890B

**AIR CHIMNEY** - The SK-806 is moulded of fiberglass-reinforced silicone resin. It effectively directs the flow of air from a pressurized chassis to the anode cooling fins with minimum pressure drop, and is recommended for use with the air-cooled tubes.

AIR-SOCKETS — Net Weight (approximate) ..... 18 oz; 510 gm

AIR CHIMNEY — Net Weight (approximate) ..... 3.2 oz; 91 gm

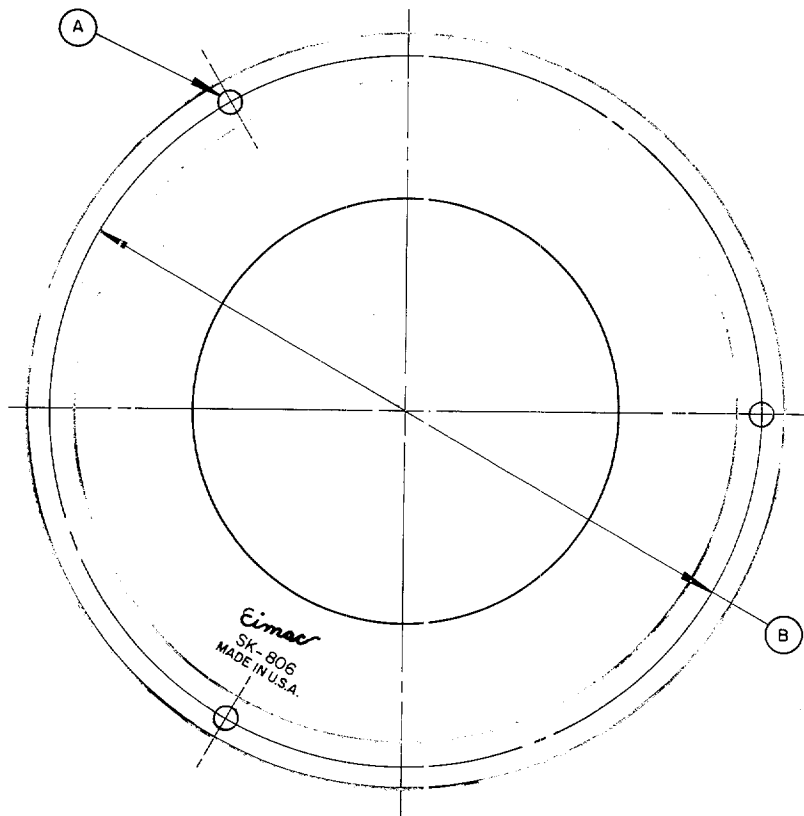

DIMENSIONAL DATA

DIM.	INCHES			MILLIMETERS		
	MIN.	MAX.	REF.	MIN.	MAX.	REF.
A	.140	.160		3.56	4.06	
B	5.575	5.615		141.60	142.62	
C	3.417	3.457		86.79	87.81	
D			.062			1.57
E	1.770	1.925		44.96	48.89	
F	.090	.150		2.29	3.81	
G	5.000	5.125		127.00	130.17	
H	6.063	6.187		154.00	157.15	

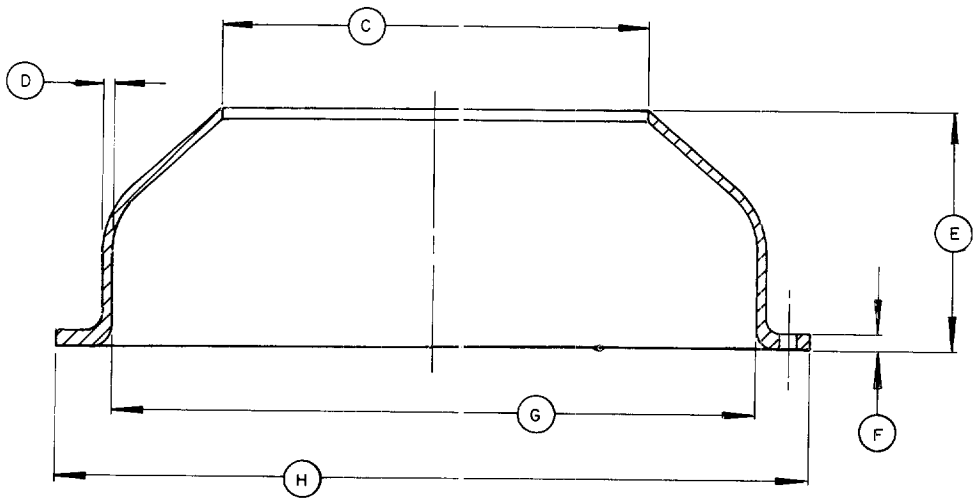



DIMENSIONAL DATA						
DIM.	INCHES			MILLIMETERS		
	MIN.	MAX.	REF.	MIN.	MAX.	REF.
A	5.290	5.330		134.37	135.38	
B	5.010	5.047		127.25	128.19	
C	.690	.730		17.53	18.54	
D	1.100	1.170		27.94	29.72	
E			.760			19.30
F	.641	.681		16.28	17.30	
G	.500	.540		12.70	13.72	
H	.110	.140		2.79	3.56	
J	.510	.540		12.95	13.72	
K	.422	.452		10.72	11.48	
L			5.595			142.11
M	.069 D	.075 D		1.75 D	1.91 D	
N	40°	42°				
P	29°	31°				
R	119°	121°				
S	1.490	1.530		37.85	38.86	
T	1.699	1.739		43.15	44.17	
U	1.917	1.957		48.69	49.71	
V	.245	.255		6.22	6.48	
W	1.032	1.072		26.72	27.23	
X	2.052	2.072		52.12	52.63	
AA	.078 D	.108 D		1.98 D	2.74 D	
AB	1.246	1.286		31.65	32.66	
AC	.156 D	.186 D		3.96 D	4.72 D	
AD			.234			5.94
AE	.125 R	.187 R		3.18 R	4.75 R	
AF	.292	.332		7.42	8.43	
AG	.292	.332		7.42	8.43	
AH	.105	.145		2.67	3.68	
AJ		.062 R			1.57 R	
AK	80°	100°				
AL	.417	.457		10.59	11.61	
AM	.142 D	.146 D		3.61 D	3.71 D	

NOTES:

- REF. DIMENSIONS ARE FOR INFO. ONLY & ARE NOT REQUIRED FOR INSPECTION PURPOSES.
- TOLERANCES ARE NOT CUMULATIVE.

