



TECHNICAL DATA

WATER COOLED
POWER TETRODE

The EIMAC 4CW50,000J is a ceramic/metal, liquid-cooled power tetrode intended for use at the 50 to 100 kilowatt output power level. This tube is characterized by low input and feedback capacitances and low internal lead inductances. A rugged mesh thoriated tungsten filament provides adequate emission over the long operating life. It is recommended for use as a Class AB₁ rf linear amplifier. The liquid-cooled anode is rated at 50 kilowatts plate dissipation.



GENERAL CHARACTERISTICS¹

ELECTRICAL

Filament: Mesh Thoriated Tungsten

Voltage	12.0 ± 0.6 V
Current, at 12.0 volts	220 A

Amplification Factor (Average):

Grid to Screen	4.5
----------------------	-----

Shown with SK-2050 Jacket
(order separately)

Direct Interelectrode Capacitances (grounded cathode):

C _{in}	310 pF
C _{out}	48 pF
C _{gp}	1.0 pF

Frequency of Maximum Rating:

CW	110 MHz
----------	---------

1. Characteristics and operating values are based upon performance tests. These figures may change without notice as the result of additional data or product refinement. EIMAC Division of Varian should be consulted before using this information for final equipment design.

MECHANICAL

Maximum Overall Dimensions:

Length (with water jacket)	12.75 in; 324 mm
Diameter	9.53 in; 242 mm

Net Weight (less water jacket)

Operating Position

Maximum Operating Temperature:

Ceramic/Metal Seals and terminals

Cooling

Base

Recommended Socket

Recommended Water Jacket

**RADIO FREQUENCY LINEAR AMPLIFIER
GRID DRIVEN Class AB**

TYPICAL OPERATION (Frequencies to 30 MHz)
Class AB1, Grid Driven
Peak Envelope or Modulation Crest Conditions

ABSOLUTE MAXIMUM RATINGS:

DC PLATE VOLTAGE	17,500 VOLTS
DC SCREEN VOLTAGE	2,500 VOLTS
DC PLATE CURRENT	12.0 AMPERES
PLATE DISSIPATION	50,000 WATTS
SCREEN DISSIPATION	1,500 WATTS
GRID DISSIPATION	400 WATTS

Plate Voltage	8.3 kVdc
Screen Voltage	1.5 kVdc
Grid Voltage ¹	-250 Vdc
Zero-Signal Plate Current	3.6 Adc
Single-Tone Plate Current	9.8 Adc
Peak rf Grid Voltage ²	250 v
Resonant Load Impedance	413 Ω
Plate Dissipation	35 kW
Plate Output Power	45 kW
Intermod. Distortion Products ³	
3rd Order	-46 dB
5th Order	-60 dB

1. Adjust to specified zero-signal dc plate current.
2. Approximate value.
3. The IMD products are referenced against one tone of a two-equal tone signal.

NOTE: TYPICAL OPERATION data are obtained from direct measurement or by calculation from published characteristic curves. Adjustment of the rf grid voltage to obtain the specified plate current at the specified bias, screen and plate voltages is assumed. If this procedure is followed, there will be little variation in output power when the tube is changed, even though there may be some variation in grid and screen current. The grid and screen currents which result when the desired plate current is obtained are incidental and vary from tube to tube. These current variations cause no difficulty so long as the circuit maintains the correct voltage in the presence of the variations in current.

RANGE VALUES FOR EQUIPMENT DESIGN

	<u>Min.</u>	<u>Max.</u>
Filament: Current at 12.0 volts	200	230 A
Interelectrode Capacitances (grounded cathode connection)		
C _{in}	290	330 pF
C _{out}	42.0	53.0 pF
C _{gp}	---	1.5 pF
Interelectrode Capacitances (grounded grid connection)		
C _{in}	113	137 pF
C _{out}	45.0	55.0 pF
C _{gk}	---	0.5 pF

APPLICATION

MECHANICAL

MOUNTING - The 4CW50,000J must be operated with its axis vertical. The base of the tube may be up or down at the convenience of the circuit designer.

SOCKET - The EIMAC socket type SK-2000 is recommended for use with the 4CW50,000J.

COOLING - Anode cooling is accomplished by circulating water through the SK-2050 water jacket. The table below lists minimum cooling water requirements at various dissipation levels.

Plate Dissipation* (kilowatts)	Water Flow (GPM)	Pressure Drop (PSI)
10	3.0	2.0
20	5.0	3.0
30	6.5	4.0
40	8.5	5.2
50	10.5	6.5

*Since the power dissipated by the filament represents about 2500 watts and since grid-plus-screen dissipation can, under some conditions, represent another 1900 watts, allowance has been made in preparing this tabulation for an additional 4400 watts dissipation.

The cooling table above assumes a water temperature rise of 20°C. Under no circumstances should the outlet water temperature exceed 70°C. Inlet water pressure should not exceed 100 psi.

A major factor affecting long life of water cooled tubes is the condition of the cooling water. If the cooling water is ionized, deposits of copper oxide will form on the internal parts of the water jacket and can cause localized heating of the anode and eventual failure of the tube.

A simple method of determining the condition of the water is to measure the resistance across a known volume. The resistance of the water should be maintained above 50 K ohms/cm³, and preferably above 250 K ohms/cm³. A relative water resistance check can be made continuously by measuring the leakage current which will bypass a short section of the insulating hose column if metal nipples or fittings are used as electrodes.

Separate cooling of the tube base is required and is accomplished by directing approximately 200 cfm of air through the socket.

ELECTRICAL

FILAMENT OPERATION - Filament voltage should be measured at the socket with a 1 percent rms responding meter. The peak emission at rated filament voltage of the EIMAC 4CW50,000J is normally many times the peak emission required for communication service. A small decrease in filament temperature due to reduction of filament voltage can increase the life of the 4CW50,000J by a substantial percentage. It is good practice to determine the nominal filament voltage for a particular application that will not adversely affect equipment operation. This is done by measuring some important parameter of performance such as plate current, power output, or distortion while filament voltage is reduced on the 4CW50,000J. At some point in filament voltage there will be noticeable reduction in plate current, or power output, or an increase in distortion. Operation must be at a filament voltage slightly higher than the point at which performance appears to deteriorate. This point should be periodically checked to maintain proper operation.

GRID OPERATION - The 4CW50,000J control grid is rated at 400 watts of dissipation. Grid dissipation is the approximate product of grid current and peak positive grid voltage.

SCREEN DISSIPATION - The power dissipated by the screen grid must not exceed 1500 watts. Where no ac is applied to the screen, dissipation is the product of dc screen voltage and dc screen

current. With screen modulation the dissipation is dependent on rms screen voltage, and rms screen current. Plate voltage, plate load or bias voltage must never be removed while filament and screen voltages are present since the screen dissipation rating will be exceeded. Suitable protective means must be provided to prevent any of these conditions.

The 4CW50,000J may exhibit reversed screen current to a greater or lesser degree depending on operating conditions. The screen supply voltage must be maintained constant for any values of negative and positive screen current which may be encountered. Dangerously high plate current may flow if the screen power supply exhibits a rising voltage characteristic with negative screen current. Stabilization may be accomplished with a bleeder resistor connected from screen to cathode, or an electron-tube regulator circuit may be employed in the screen supply. It is absolutely essential to use a bleeder if a series electron-tube regulator is employed.

PLATE DISSIPATION - The plate dissipation of 50 kilowatts attainable through water cooling provides a large margin of safety in most applications. The rating may be exceeded for brief periods during tuning. When the 4CW50,000J is used as a plate-modulated rf amplifier, plate dissipation under carrier conditions is limited to 33,300 watts.

STANDBY OPERATION - Coolant must be circulated through the anode water jacket whenever filament power is applied even though no other voltages are present. Sixty to eighty percent of the filament power appears as heat in the anode. In the absence of coolant flow, temperatures will rise to levels which are detrimental to long life. If the coolant lines are obstructed the coolant jacket may rupture from the generated steam pressure.

HIGH VOLTAGE - Normal operating voltages used with the 4CW50,000J are deadly, and the equipment must be designed properly and operating precautions must be followed. Design all equipment so that no one can come in contact with high voltages. All equipment must include safety enclosures for high-voltage circuits and terminals, with interlock switches to open primary circuits of the power supply and to discharge high-voltage condensers whenever access doors are opened. Interlock switches must not be bypassed or "cheated" to allow operation with access doors open. Always remember that HIGH VOLTAGE CAN KILL.

X-RADIATION - High-vacuum tubes operating at voltages higher than 10 kilovolts produce progressively more dangerous X-ray radiation as the voltage is increased. The 4CW50,000J, operating at its rated voltages and currents, is a potential X-ray hazard. Only limited shielding is afforded by the tube envelope. Moreover, the X-ray radiation level can increase significantly with aging and gradual deterioration, due to leakage paths or emission characteristics as they are effected by the high voltage. X-ray shielding must be provided on all sides of tubes operating at these voltages to provide adequate protection throughout the tube's life. Periodic checks on the X-ray level should be made, and the tube should never be operated without adequate shielding in place when voltages above 10 kilovolts are in use. Lead glass, which attenuates X-rays, is available for viewing windows. If there is any doubt as to the requirement for or the adequacy of shielding, an expert in this field should be contacted to perform an X-ray survey of the equipment.

Operation of high-voltage equipment with interlock switches "cheated" and cabinet doors open in order to be better able to locate an equipment malfunction can result in serious X-ray exposure.

RADIO FREQUENCY RADIATION - Avoid exposure to strong rf fields even at relatively low frequency. Absorption of rf energy by human tissue is dependent on frequency. Under 30 MHz, most of the energy will pass completely through the human body with little attenuation or heating effect. Public health agencies are concerned with the hazard, however, even at these frequencies,

and it is worth noting that some commercial dielectric heating units actually operate at frequencies as low as the 13 and 27 MHz bands.

Many EIMAC power tubes, such as the 4CW-50,000J, are specifically designed to generate or amplify radio frequency power. There may be a relatively strong rf field in the general proximity of the power tube and its associated circuitry---the more power involved, the stronger the rf field. Proper enclosure design and efficient coupling of rf energy to the load will minimize the rf field in the vicinity of the power amplifier unit itself.

FAULT PROTECTION - In addition to normal plate over-current interlock, screen current interlock, and coolant flow interlock, it is good practice to protect the tube from internal damage which could result from occasional plate arcing at high anode voltage.

In all cases some protective resistance, 5 ohms to 25 ohms, should be used in series with each tube anode to absorb power supply stored energy in case a plate arc should occur. If power supply stored energy exceeds 750 watt seconds, we strongly recommend use of some form of electronic crowbar which will discharge power supply capacitors in a few microseconds following indication of start of a plate arc.

SPECIAL APPLICATION - Where it is desired to operate this tube under conditions widely different from those listed here, write to Power Grid Tube Division, EIMAC Division of Varian, 301 Industrial Way, San Carlos, California 94070 for information and recommendations.

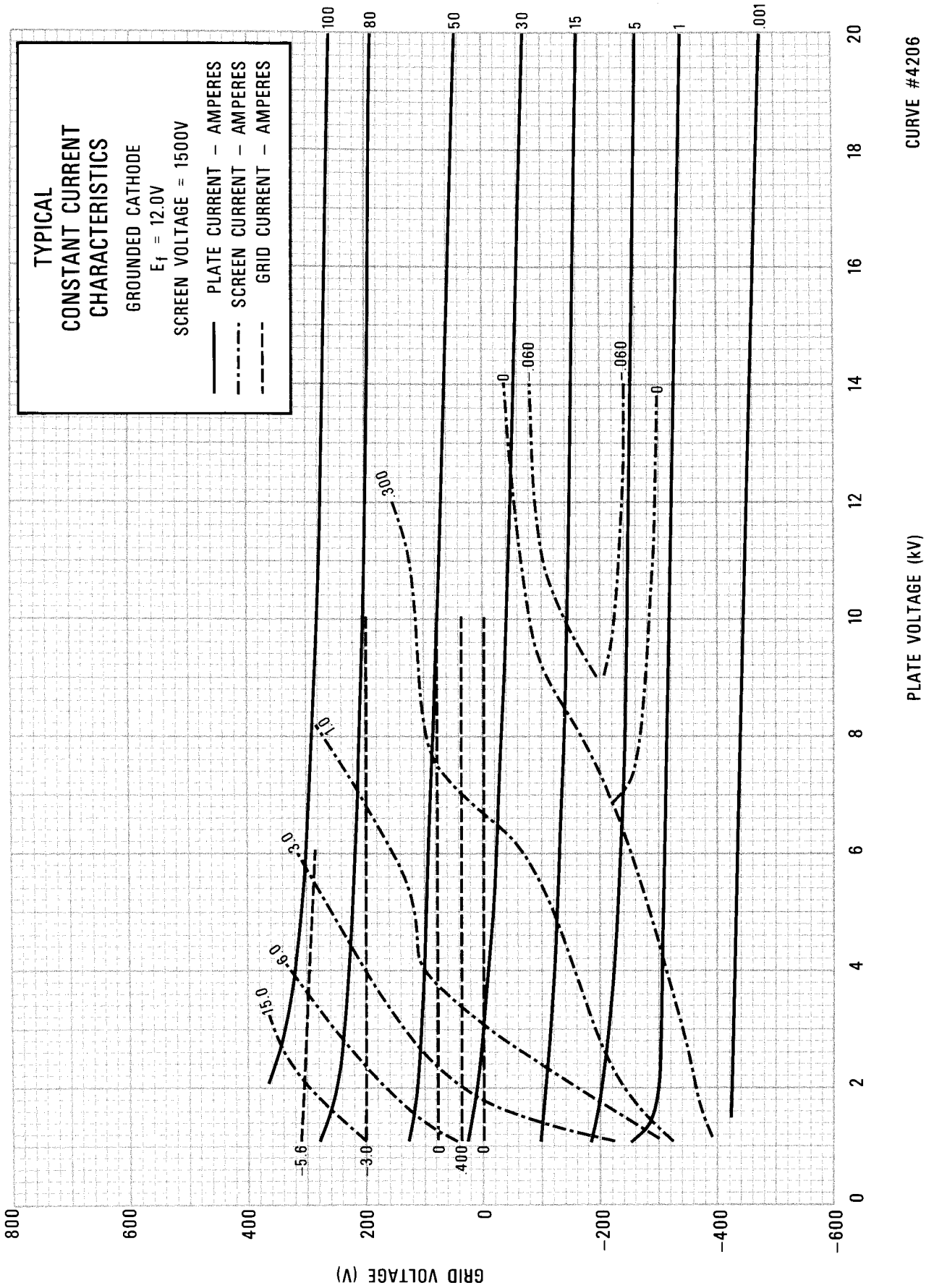

CURVE #4206

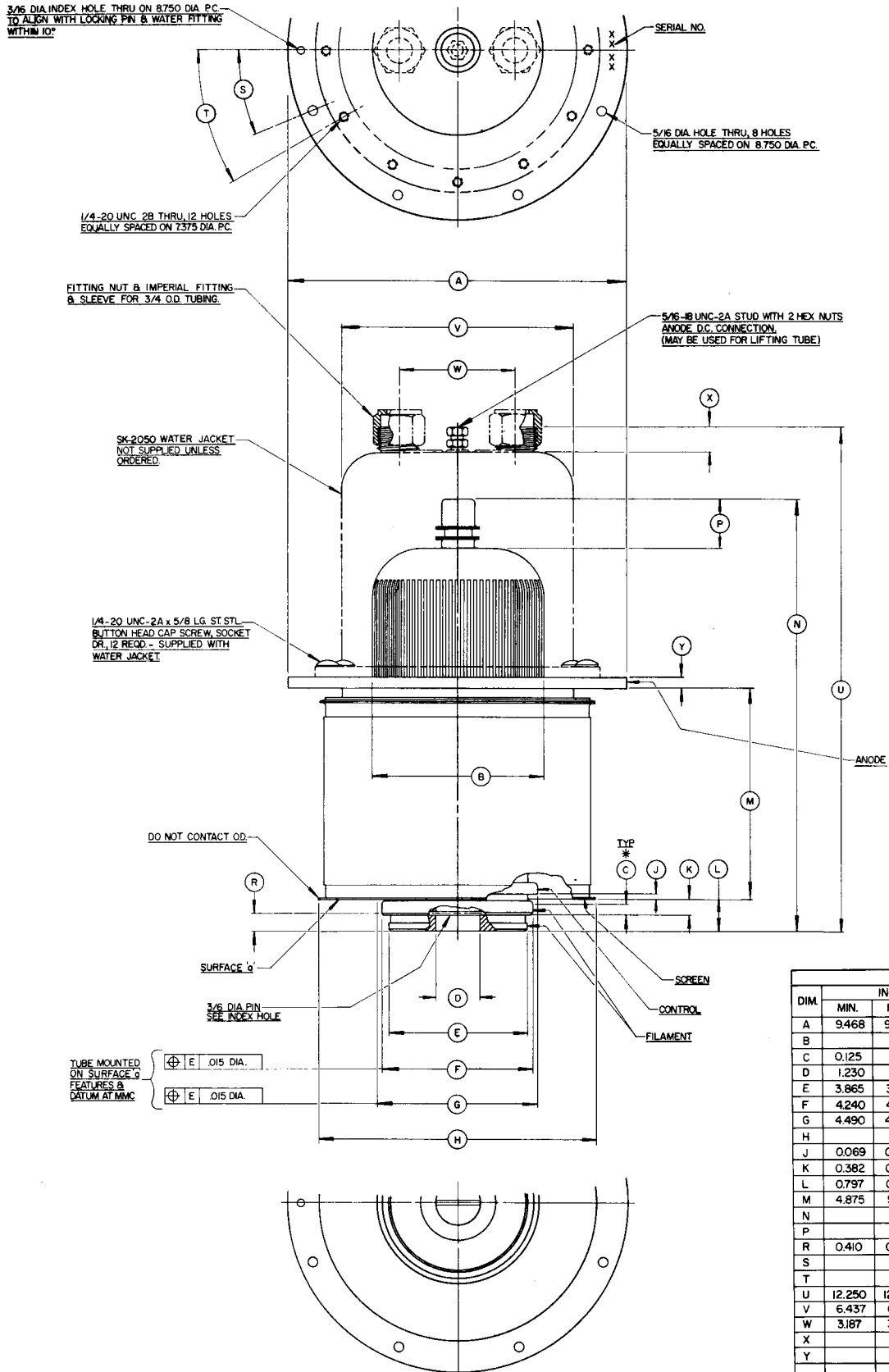

DIM.	INCHES			MILLIMETERS		
	MIN.	MAX.	REF.	MIN.	MAX.	REF.
A	9.468	9.531		240.49	242.09	
B			5.000			127.00
C	0.125			3.18		
D	1.230	1.270		31.24	32.26	
E	3.865	3.885		98.17	98.68	
F	4.240	4.260		107.70	108.20	
G	4.490	4.510		114.05	114.55	
H			7.750			196.85
J	0.069	0.149		1.75	3.78	
K	0.382	0.462		9.70	11.73	
L	0.797	0.922		20.24	23.42	
M	4.875	5.000		123.83	127.00	
N			11.500			292.10
P			1.437			36.50
R	0.410	0.475		10.41	12.07	
S			22.5°			22.5°
T			30°			30°
U	12.250	12.750		311.15	323.85	
V	6.437	6.562		163.50	166.67	
W	3.187	3.313		80.95	84.15	
X			0.562			14.27
Y			0.312			7.92

NOTES:
 1. REF. DIMENSIONS ARE FOR INFO. ONLY & ARE NOT REQUIRED FOR INSPECTION PURPOSES.